

FROM PAGE 1 - ENGINE CONNECTOR

FROM PAGE 1 -
POWER
CONNECTOR

- | | |
|----|----------------|
| 1 | 2503L |
| 2 | 2205N |
| 3 | 2206N |
| 4 | 2207N |
| 5 | 2208N |
| 6 | 2209N |
| 7 | 2210N |
| 8 | 2405M |
| 9 | 2406M |
| 10 | 2412M |
| 11 | 2411M |
| 12 | 2410M |
| 13 | 2409M |
| 14 | 2215M |
| 15 | 2211N |
| 16 | 2203N |
| 17 | 2220N |
| 18 | 2301N |
| 19 | 2203N |
| 20 | 2203N |
| 21 | 1506L |
| 22 | 2221N |
| 23 | 1705M |
| 24 | 2213N |
| 25 | J1939 HIGH (+) |
| 26 | J1939 LOW (-) |
| 27 | 1705M |
| 28 | 2213N |
| 29 | 2213N |

CUMMINS ENGINE
CONTROL SYSTEM

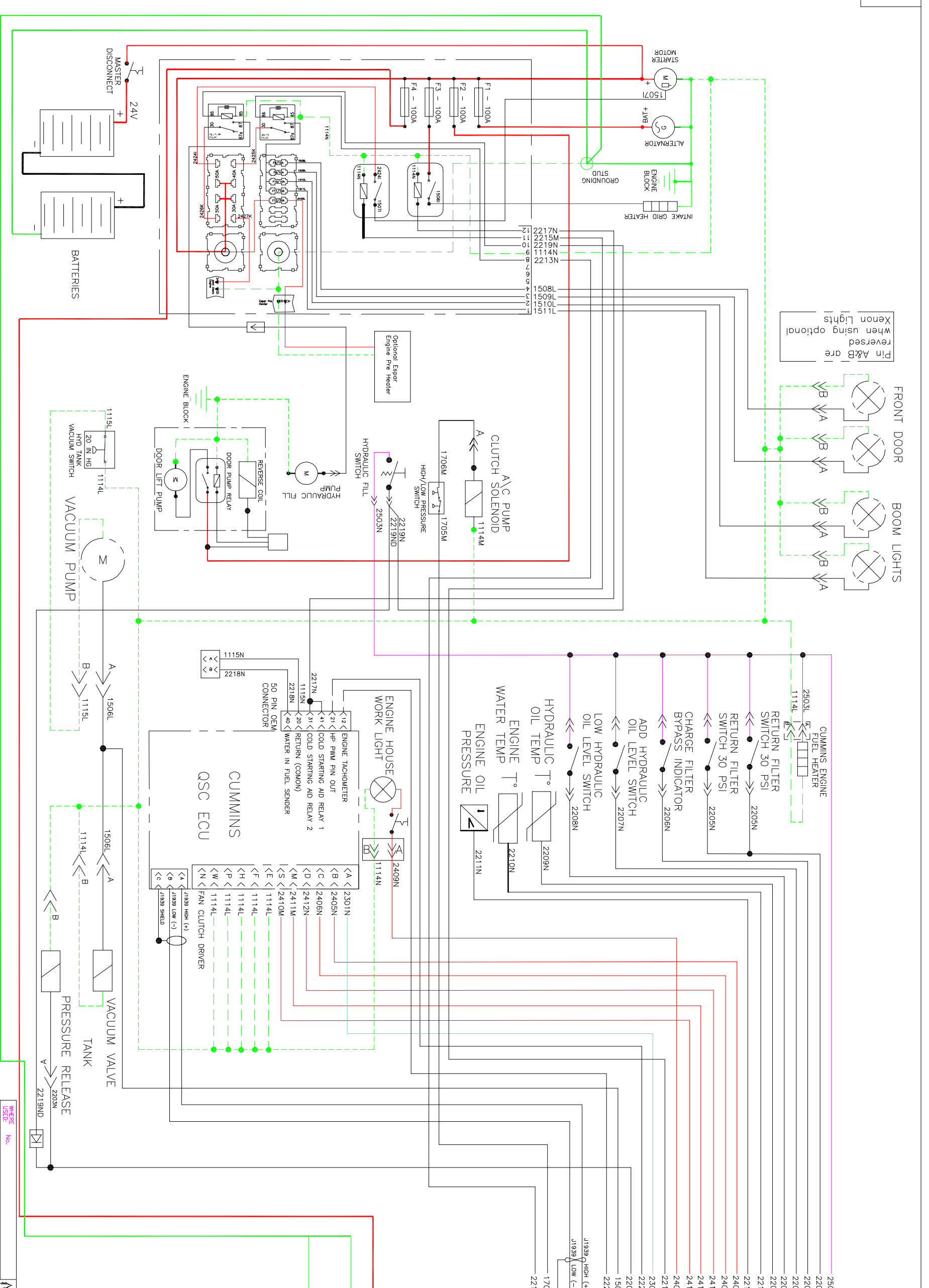

THIS DRAWING IS THE PROPERTY OF TIMBERPRO, LLC AND REPRODUCTION OR DISSEMINATION OF THIS DRAWING WITHOUT THE WRITTEN PERMISSION OF TIMBERPRO, LLC IS STRICTLY PROHIBITED.

REV.	DESCRIPTION	BY	DATE

TITLE	
DATE	
SCALE	
SHEET	