

Section 8.1



Lower Solenoid Manifold Circuits

Lower Solenoid Manifold Explanation	8.1.2
Lower Manifold Solenoids	8.1.3
Lower Solenoid Manifold Circuit Diagram	8.1.5
Lower Solenoid Manifold Schematic	8.1.6

Lower Solenoid Manifold

The lower solenoid manifold is the heart of several auxiliary control circuits found in the lower frame area, including:

- A) Axle Differential Lock
- B) Wheel Motor Shift
- C) Parking Bakes
- D) Gearbox Shift
- E) Frame Lock Brake
- F) Travel Brake

The lower solenoid manifold is located in the lower frame. It includes two pressure reducing valves, two relief valves, six solenoid valves, one check valve, and two pilot operated check valves. See Figures 1 and 2.

A small gear pump located on the charge pump is directed through the rotary manifold and supplies oil to port P of the lower solenoid manifold. The oil then is reduced in pressure to 2000 psi (137.9 bar) for the travel brake and frame lock circuits. This pressure setting can be checked by using port "G1".

This same pressure is then also reduced to 900 psi (62 bar) for the parking brake. The parking brake pressure can be check by using port "PBG"

The incoming pressure is also reduced to 425 psi (29.3 bar) for the motor shift, gear box shift, and differential lock.

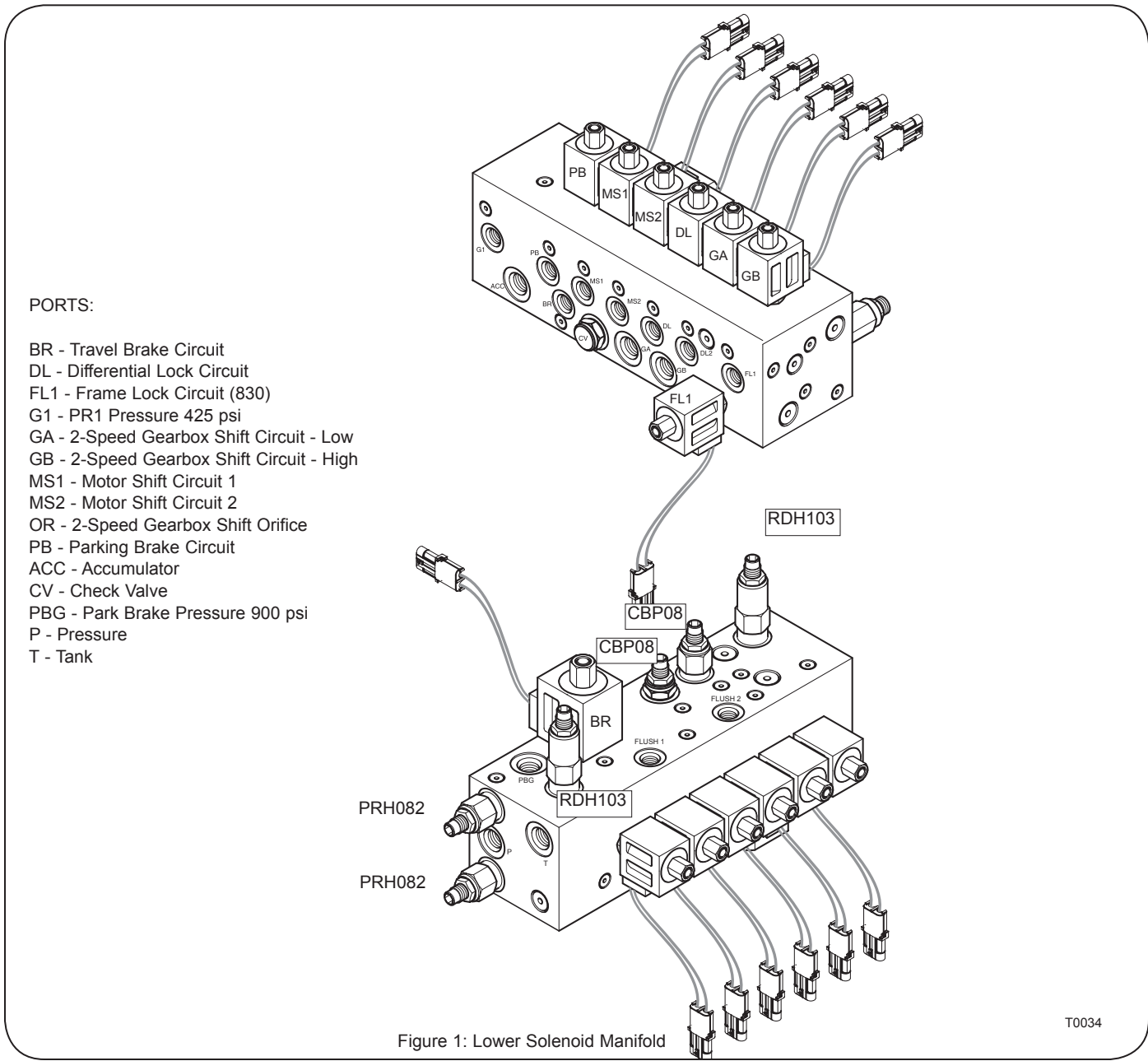

Lower Manifold Solenoid Valves

Most of the solenoid valves found in the lower solenoid manifold are the replaceable cartridge type equipped with 24-volt ON/OFF coils. The solenoid valves are “normally closed” and vent the auxiliary circuits to tank when the coil is not energized.

Parking Brake Circuit

The “PB” solenoid is a On/Off coil controlled by the IQAN control system. (See Section 4.2 in this manual for information)

The IQAN system supplies power to the parking brake coil when ever the wheel drive pedal is depressed or when the auto parking brake switch is in the “OFF” position.

The cab door must be closed and the IQAN system must be armed before the IQAN system will supply power to the coil and release the parking brake.

The parking brakes are mechanical spring applied and need hydraulic pressure to release.

NOTE: The machine parking brake should always be set when parking the machine after the work shift. This prevents the brakes from being released on machine startup.

Wheel Drive Motor Shift Circuit

The **MS1** and **MS2** solenoids are On/Off coils controlled by the IQAN control system and the hydraulic motor shift switch located on the right joystick control panel.(See Section 4.2 in this manual for information)

When the Motor Shift Switch is in the “**Low**” position both MS1 and MS2 solenoid coils are energized and both motor shift valve are shifted allowing 425 psi (29.3 bar) to shift both hydraulic motors to “Max displacement. This position offers the most power and torque available from the motors but decreases machine speed.

NOTE: Max displacement offers the most torque and forces low speed travel. Low speed should be used when loading/unloading the machine and when operating on soft, rough or uneven ground.

When the Motor Shift Switch is in the “**Med**” or “**Down Hill**” position MS1 coil is energized and

MS2 solenoid coil is de-energized. In this condition the MS1 valve is shifted allowing 425 psi (29.3 bar) to the shift port on the front hydraulic motor to Max displacement. The MS2 valve is de-energized and the rear motor is vented to tank allowing it to be in Min displacement. This position works well when running the machine on steep slopes or uneven ground to help prevent an Over-Speed condition but still being able to reach faster travel speed.

When the Motor Shift Switch is in the “**High**” position both MS1 and MS2 solenoid coils are de-energized and the motor shift lines are vented to tank. This position allows both motors to be in “Min” displacement. Min displacement will allow the machine to reach higher speeds but less torque. This should only be used when traveling on flat or smooth terrain.

NOTE: Min displacement offers the least amount of torque but allows a faster travel speed. Min displacement should only be used in flat or smooth terrain.

Axle Differential Lock Circuit

The **DL** solenoid is a On/Off coil controlled by the IQAN control system and the Differential Lock switch located on the left joystick control panel. (See Section 4.2 in this manual for information)

When the differential lock switch is activated, the coil is energized and the valve opens. This allows 425 psi (29.3 bar) of pressure to overcome a mechanical spring force and the differential lock is engaged.

The differential lock is a mechanical gear lock located in the front and rear axle differential. When the differential lock is activated all six (TB 630) or eight wheels (TF 830) are physically locked in and will provide traction. Because this can be hard on the axles and steering components. The differential lock should only be used when needed and should never be used when driving on hard surfaces.

NOTE: Always fully stop the machine before engaging or disengaging the axle differential lock. Failure to do so could result in major differential damage.

Gearbox Shift Circuit

The **GA** and **GB** solenoids are On/Off coils controlled by the IQAN control system and the Gear Box shift switch located on the right joystick control panel. (See Section 4.2 in this manual for information)

When the Gear Box Shift Switch is in the “**Low**” position the GA solenoid coil is energized and the GA valve is shifted allowing 425 psi (29.3 bar) to shift the gear box cylinder to the low gear position.

When the Gear Box Shift Switch is in the “**High**” position the GB solenoid coil is energized and the GB valve is shifted allowing 425 psi (29.3 bar) to shift the gear box cylinder to the high gear position.

The gearbox shifting mechanism is basically a double-acting cylinder attached to a shifting fork. A control pressure signal line is connected between each side of the cylinder and one of the positions of the valve. Between the cylinder and valve are dual pilot-operated check valves which keep the gearbox from slipping out of gear if the hydraulic pressure were to suddenly drop or bleed away.

The gear box also has two limit switches located in the shifting cylinder that provide the cylinder position information back to the IQAN control system and stop the machine from being able to move until the gear shift collar is fully engaged. This is done to prevent damage to the internal gears and shifting collar. When the IQAN system senses that the shifting cylinder is not fully engaged in low or high gear a message is displayed on the IQAN MDM screen warning the operator that the “**Machine is not in Gear**”.

NOTE: Because the gear box shifting mechanism is a mechanical gear change the machine needs to be fully stopped when changing gears. The parking brake switch should also be turned “Off” and the operator should steer the machine to help the shifting collar teeth to line up with the gears.

NOTE: Pressure will always be trapped in the connections between the gearbox shift cylinder and lower solenoid manifold due to the pilot operated check valves in the circuit (even with the engine shutdown). Open these connections with care to avoid injury from escaping oil under pressure.

Frame Lock (TF 830/840)

The **FL** solenoid is an On/Off coil controlled by the IQAN control system. As soon as the machine is started the IQAN system energizes the frame lock coil.

When the wheel drive travel pedal is actuated, the frame lock coil is de-energized. This vents the frame lock caliper and allows the front and rear frame to move independently when traveling over uneven terrain. As soon as the wheel drive pedal is released the coil is energized and the frame lock valve is shifted allowing 2000 psi (137.9 bar) to the frame lock brake caliper. This locks the front and rear frame together allowing the machine to be more rigid and help increase the stability and lifting capacity of the machine.

NOTE: Because the frame lock relies upon pump pressure and electrical current to be active. Always booms, attachments, and any loads on the ground before shutting down the machine. Failure to do so may cause machine to tip towards the load.

Travel Brake Circuit

The **BR** solenoid is an proportional coil controlled by the IQAN control system and the operator’s cab brake pedal. (See Section 4.2 in this manual for information)

When the brake pedal is depressed the IQAN system monitors the position of the brake pedal and sends a current controlled output to the travel brake coil. The harder the brake pedal is depressed the more current is sent to the coil. The higher the current sent to the coil the higher the pressure allowed out to the travel brake piston on the axles.

To prevent harm to the operator. The brake pedal is designed that if the connection from the brake pedal to the IQAN system is broken it will automatically turn on the travel brakes.

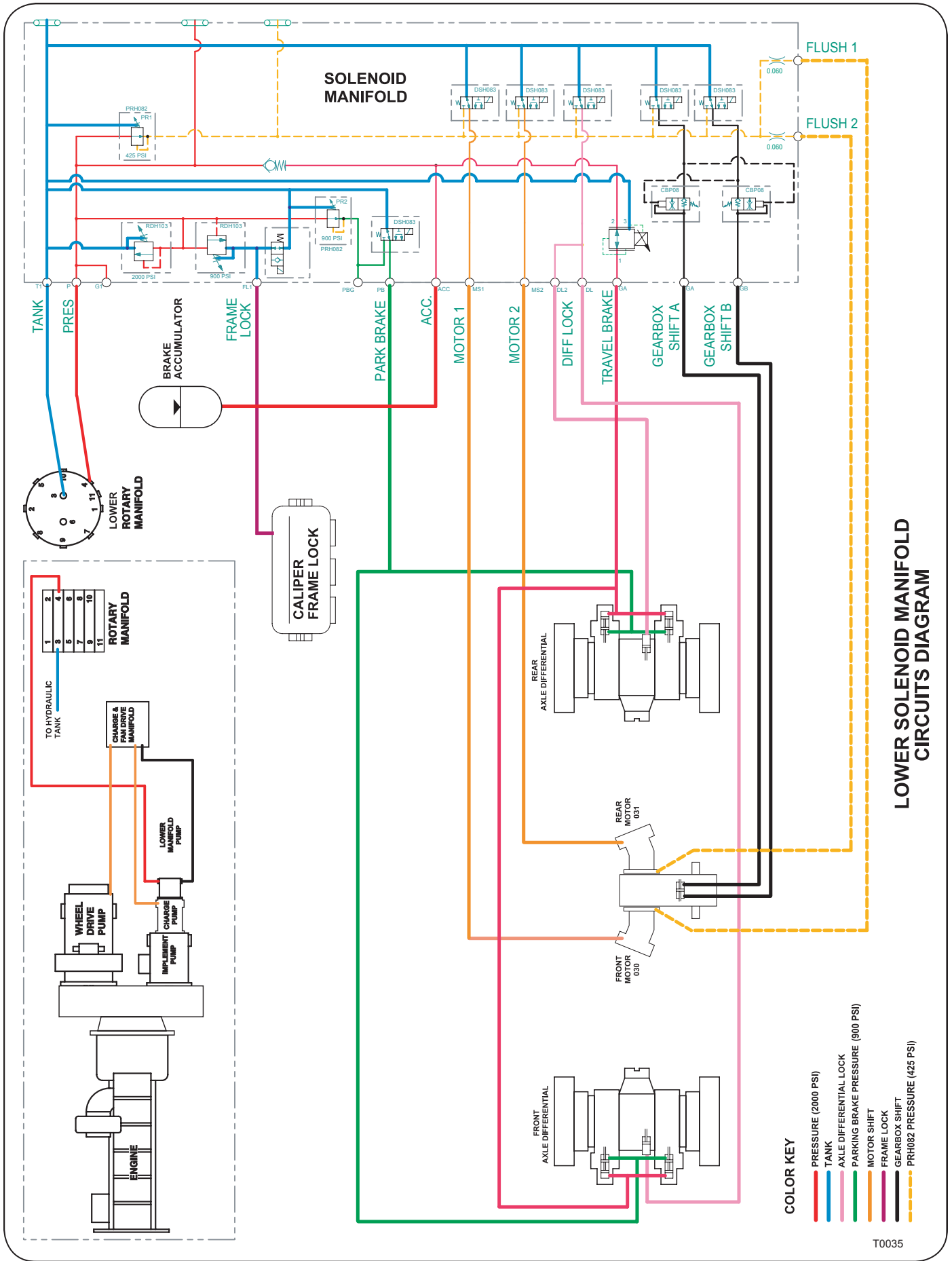
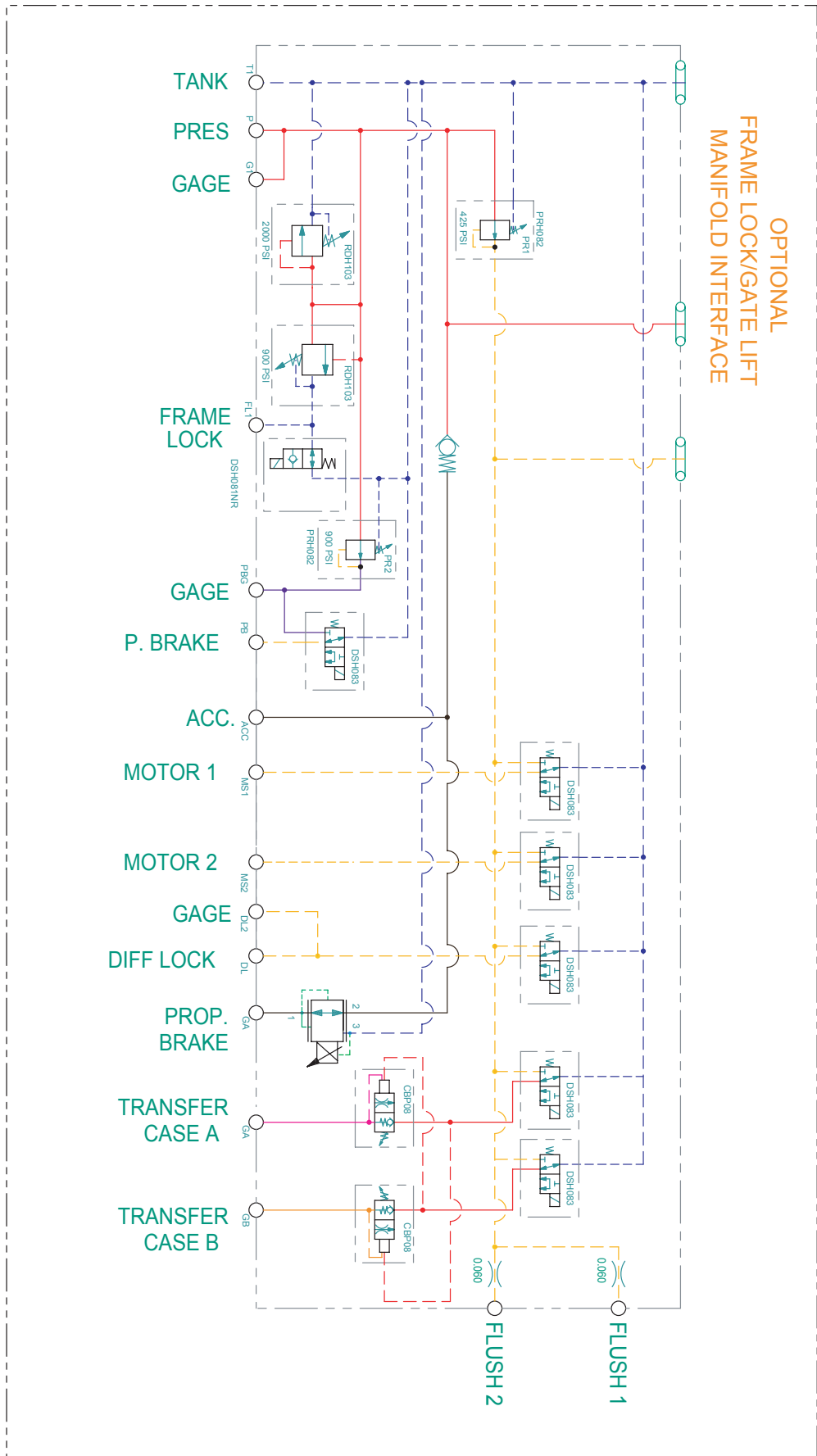

Figure 2: Lower Solenoid Manifold Circuits Diagram



T0033

Figure 3: Lower Solenoid Manifold Schematic