

TF820-D Forwarder

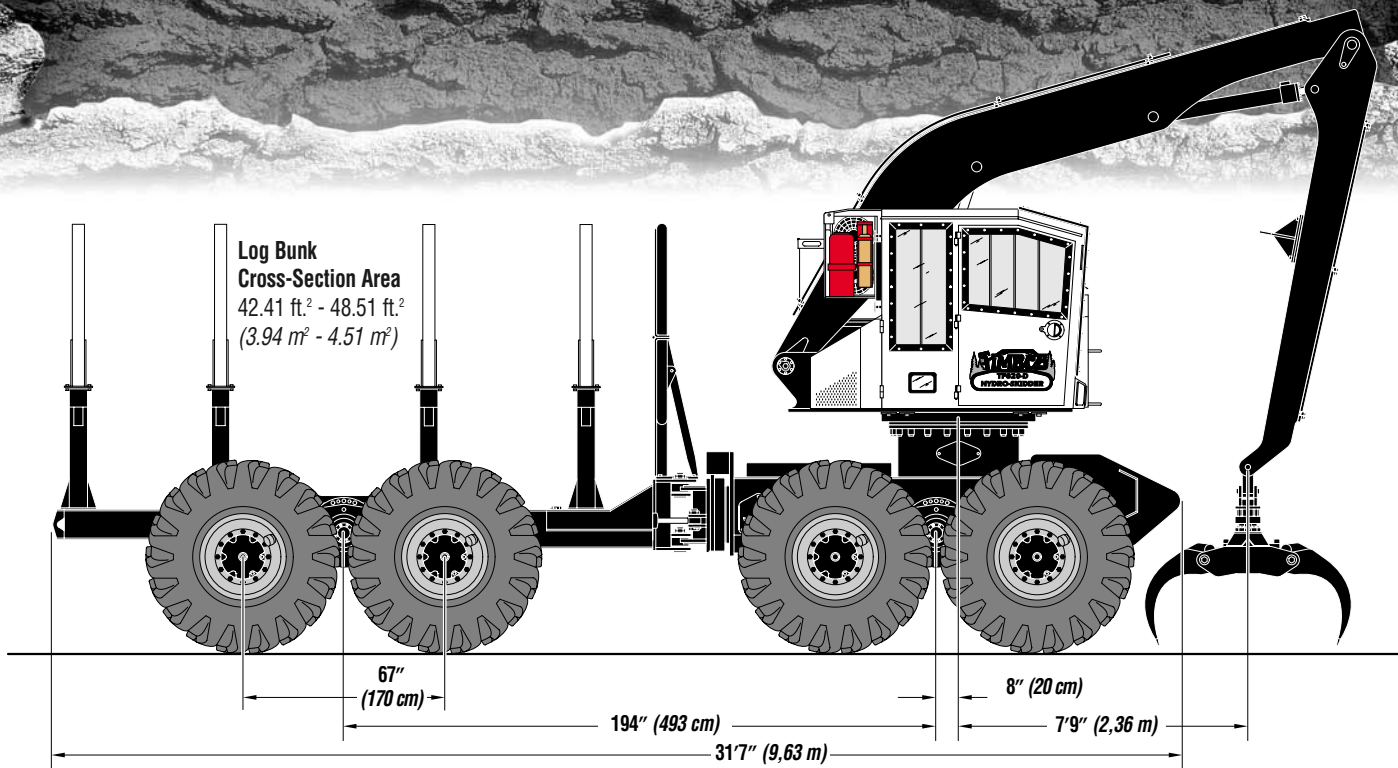

"D" Model Improvements & Features

- Short center-to-center axle design for better maneuverability and smaller turning diameter.
- "Clear-view" cab design for better visibility of load in the air.
- Bronze tint in all cab windows.
- High capacity radiator/oil cooler design for maximum cooling.
- Heavy-duty frame lock caliper brake.
- Fuel tank below rotation for easier refueling.
- 6-section main control valve is located behind operator's cab. Centralized hydraulic pressure checks.
- Pump drive speed increaser allows lower engine RPM for fuel efficiency and noise reduction.

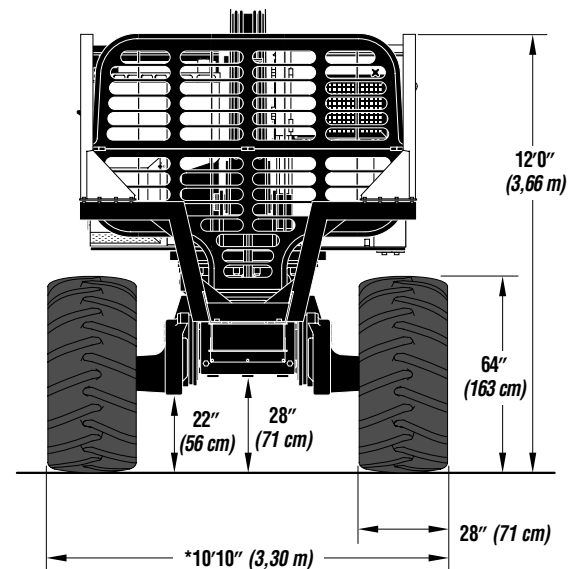

Lift Capacities (w/Hultdin's 360S grapple)

Radius	Lift Capacity
10' (3,05 m)	9,600 lb. (4 355 kg)
15' (4,57 m)	6,700 lb. (3 039 kg)
20' (6,10 m)	5,000 lb. (2 268 kg)
25' (7,62 m)	3,100 lb. (1 406 kg)

Lift capacities shown are with a Hultdins Supergrip 360S grapple with GV17US indexator [800 lb. (363 kg)].

*9'7" (2,92 m)
with rim dish turned in.

Axle Weight - Front 33,860 lb. (15 359 kg)
Axle Weight - Rear 17,960 lb. (8 147 kg)
Base Machine Weight 51,820 lb. (23 506 kg)

Approximate "woods ready" operating weight, fully serviced including 1/2 full fuel tank [57gal. (216 litres) @ 467 lb. (207 kg)] and 175 lb. (80 kg) operator.



TF820-D Forwarder

Standard Equipment

- N.A.F. gear drive dual bogie axles with differential lock, Firestone 28L-26/14 ply tires, and 40,000 lb. (18 144 kg) capacity.
- Superior custom designed gearbox.
- Hydrostatic wheel drive with a Rexroth 125cc 80 gpm (303 litres) pump and Rexroth A6VM160 2-speed auto-shift drive motors with 53,795 lb. (24 401 kg) drawbar pull and 0-9.0 mph (14.48 km/h) travel speed.
- Cummins C8.3-C 260HP (193 kW) Elite engine with 130 Amp alternator.
- Rexroth AA11V095 62 gpm (235 litres) implement pump and 6-section VOAC LS90 main control valve.
- Excellent component accessibility for easy service and maintenance.
- Strongest, safest cab in the industry with full ROPS/FOPS/OPS certification, excellent visibility, 3 emergency escapes, and rubber isolator mounted for sound suppression. Other features include a Red Dot air conditioner and heater, AM/FM radio with cassette, and full halogen lighting package.
- 115 gal. (435 litres) fuel capacity.

Optional Equipment

- 4 different wheel combinations including a dual wheel configuration.
- Several different grapple/grapple saw configurations including Hultdin's Supergrip 360S or 520S with GV17US rotator and Supergrip TL430 with R10 rotator.
- Fire Suppression system.
- Up to 2 additional auxiliary loader functions.
- Cold weather starting aids.
- Grapple snubber.
- Stick boom heel
- Hydraulics only for clam bunk installation.
- Extended machine warranty.

Sold and Serviced By:

Ground Pressures

	Front Axle Empty / Max. Load	Rear Axle Empty / Max. Load	Front Axle w/Tracks Empty / Max. Load	Rear Axle w/Tracks Empty / Max. Load
Firestone 28L-26 (Standard).....	9.17 psi / 9.82 psi	4.86 psi / 14.34 psi	6.27 psi / 6.66 psi	3.70 psi / 9.35 psi
Firestone 28L-26 & 23.1 Dual.....	5.53 psi / 5.89 psi	3.15 psi / 8.39 psi	-----	-----
Firestone 700/50-26.5.....	15.45 psi / 16.59 psi	7.94 psi / 24.48 psi	7.52 psi / 8.01 psi	4.26 psi / 11.54 psi
Nokian 750/55-26.5.....	11.97 psi / 12.84 psi	6.25 psi / 18.84 psi	6.48 psi / 6.89 psi	3.75 psi / 9.76 psi
Firestone 54 x 37.....	9.25 psi / 9.90 psi	4.93 psi / 14.44 psi	-----	-----



TF820-D Clam Bunk

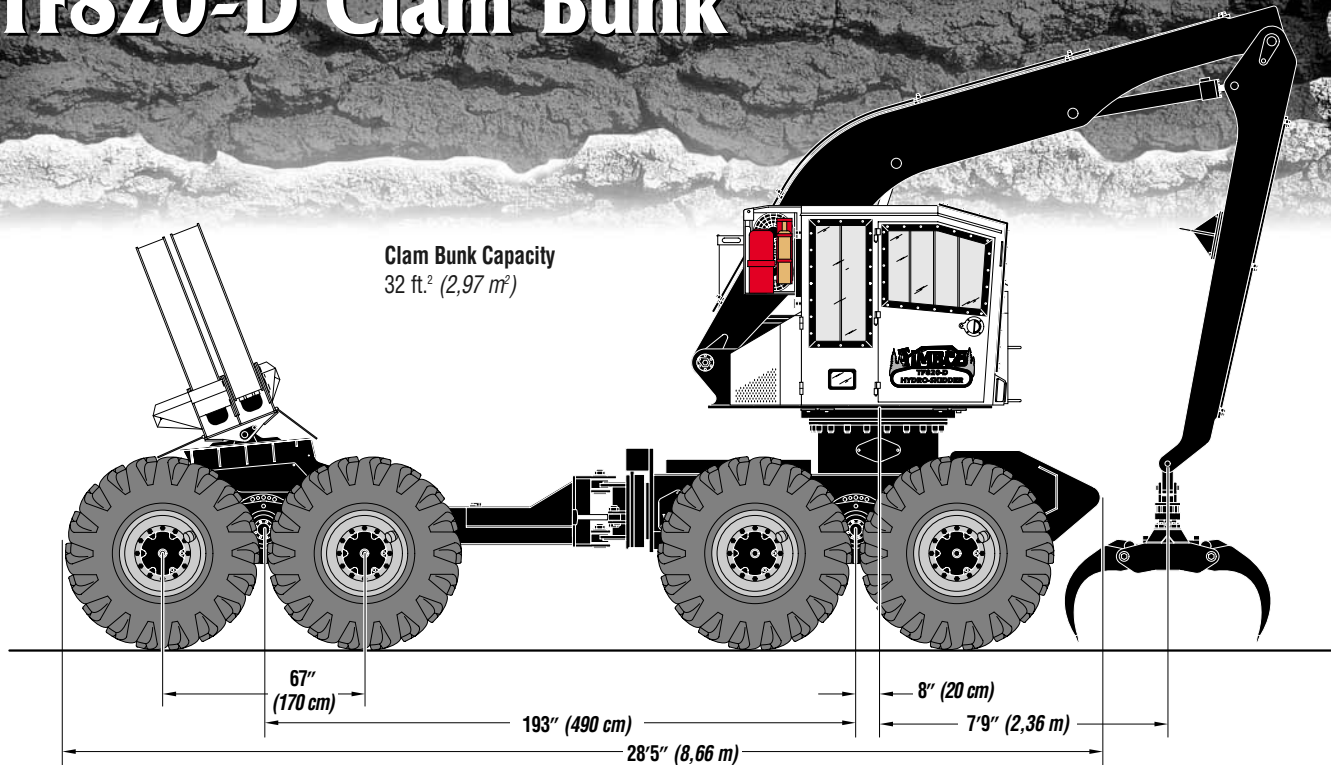

"D" Model Improvements & Features

- Short center-to-center axle design for better maneuverability and smaller turning diameter.
- "Clear-view" cab design for better visibility of load in the air.
- Bronze tint in all cab windows.
- High capacity radiator/oil cooler design for maximum cooling.
- Thicker and rounded clam bunk arm tips for greater durability.
- Heavy-duty frame lock caliper brake.
- Fuel tank below rotation for easier refueling.
- 6-section main control valve is located behind operator's cab. Centralized hydraulic pressure checks.
- Pump drive speed increaser allows lower engine RPM for fuel efficiency and noise reduction.

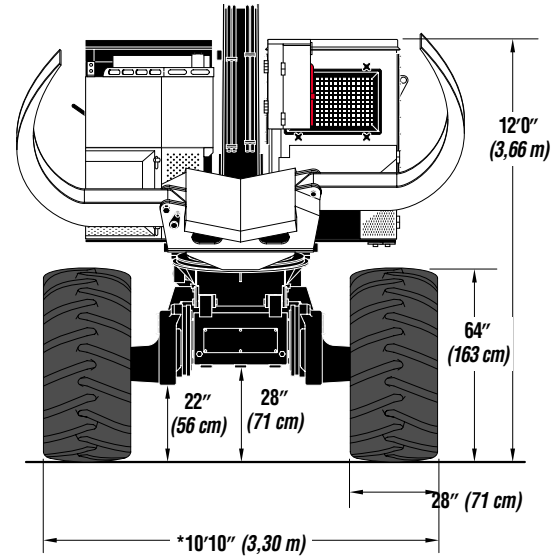

Lift Capacities (w/Hultdin's 360S grapple)

Radius	Lift Capacity
10'	9,600 lb. (4 355 kg)
15'	6,700 lb. (3 039 kg)
20'	5,000 lb. (2 268 kg)
25'	3,100 lb. (1 406 kg)

Lift capacities shown are with a Hultdin Supergrip 360S grapple with GV15US indexator [800 lb. (363 kg)].

*9'7" (2,92 m)
with rim dish turned in.

Axle Weight - Front 33,660 lb. (15 268 kg)
Axle Weight - Rear 19,460 lb. (8 827 kg)
Base Machine Weight 53,120 lb. (24 095 kg)

Approximate "woods ready operating weight, fully serviced including 1/2 full fuel tank [57 gal. (216 litres) @ 467 lb. (207 kg) and 175 lb. (80 kg) operator].



TF820-D Clam Bunk

Standard Equipment

- N.A.F. gear drive dual bogie axles with differential lock, Firestone 28L-26/14 ply tires, and 40,000 lb. (18 144 kg) capacity.
- Superior custom designed gearbox.
- Hydrostatic wheel drive with a Rexroth 125cc 80 gpm (303 litres) pump and Rexroth A6VM160 2-speed auto-shift drive motors with 53,715 lb. (24 401 kg) drawbar pull and 0-9.0 mph (14,48 km/h) travel speed.
- Cummins C8.3-C 260HP (193 kW) Elite engine with 130 Amp alternator.
- Rexroth AA11V095 62 gpm (235 litres) implement pump and 6-section VOAC LS90 main control valve.
- 32 sq. ft. (2.97 m²) capacity clam bunk.
- Excellent component accessibility for easy service and maintenance.
- Strongest, safest cab in the industry with full ROPS/FOPS/OPS certification, excellent visibility, 3 emergency escapes, and rubber isolator mounted for sound suppression. Other features include a Red Dot air conditioner and heater, AM/FM radio with cassette, and full halogen lighting package.
- 115 gal. (435 litres) fuel capacity.

Optional Equipment

- 4 different wheel combinations including a dual wheel configuration.
- Several different grapple/grapple saw configurations including Hultdin's Supergrip 360S or 520S with GV17US rotator and Supergrip TL430 with R10 rotator.
- Fire Suppression system.
- Up to 2 additional auxiliary loader functions.
- Cold weather starting aids.
- Grapple snubber.
- Stick boom heel
- Extended machine warranty.

Sold and Serviced By:

Ground Pressures

	Front Axle Empty / Max. Load	Rear Axle Empty / Max. Load	Front Axle w/Tracks Empty / Max. Load	Rear Axle w/Tracks Empty / Max. Load
Firestone 28L-26 (Standard)	9.12 psi / 9.12 psi.....	5.27 psi / 10.69 psi.....	6.24 psi / 6.24 psi.....	3.95 psi / 7.17 psi
Firestone 28L-26 & 23.1 Dual	5.50 psi / 5.50 psi.....	3.37 psi / 6.37 psi	- - -	- - -
Firestone 700/50-26.5	15.36 psi / 15.36 psi.....	8.65 psi / 18.10 psi.....	7.48 psi / 7.48 psi.....	4.57 psi / 8.67 psi
Nokian 750/55-26.5	11.90 psi / 11.90 psi.....	6.79 psi / 13.99 psi.....	6.45 psi / 6.45 psi.....	4.01 psi / 7.44 psi
Firestone 54 x 37	9.20 psi / 9.20 psi.....	5.35 psi / 10.77 psi	- - -	- - -



TS820-D Arch Grapple

Arch Grapple Area
25 ft.² (2,32 m²)

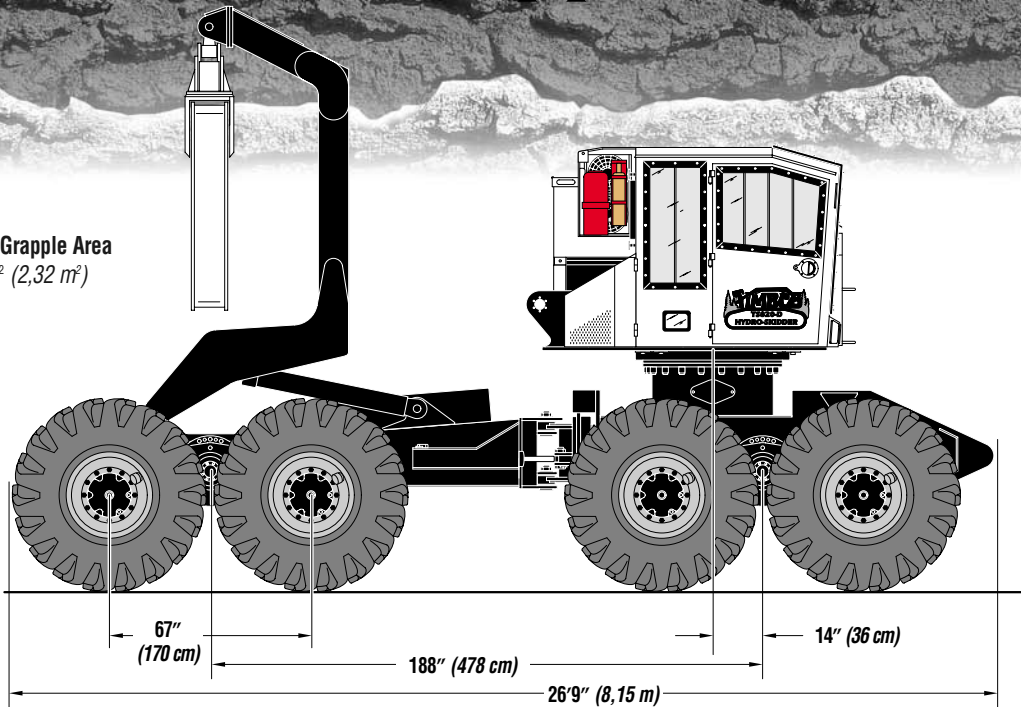

"D" Model Improvements & Features

- Short center-to-center axle design for better maneuverability and smaller turning diameter.
- Bronze tint in all cab windows.
- High capacity radiator/oil cooler design for maximum cooling.
- Fuel tank below rotation for easier refueling.
- 6-section main control valve is located behind operator's cab. Centralized hydraulic pressure check.
- Pump drive speed increaser allows lower engine RPM for fuel efficiency and noise reduction.
- Set back center of rotation and wheel drive motors moved to rear frame for better weight distribution.

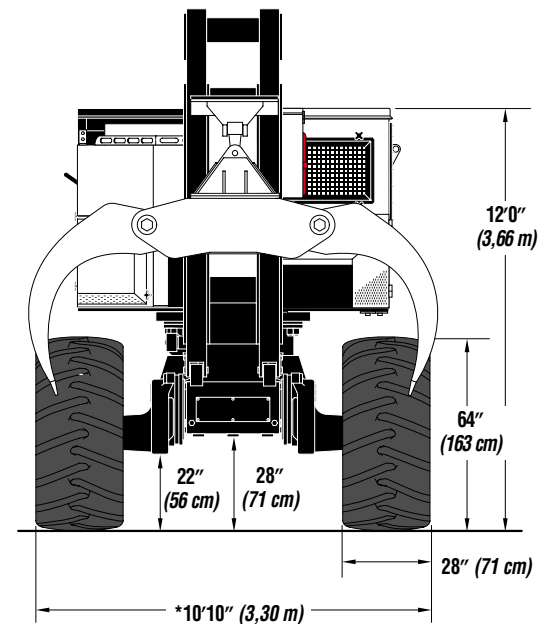
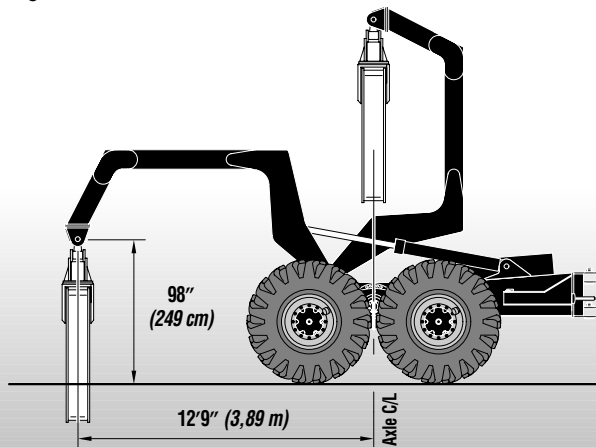

Axle Weight - Front 30,240 lb. (13 716 kg)
Axle Weight - Rear 21,520 lb. (9 760 kg)
Base Machine Weight 51,760 lb. (23 476 kg)

Approximate "woods ready" operating weight, fully serviced including 1/2 full fuel tank [55 gal. (208 litres) @ 451 lb. (186 kg)] and 175 lb. (80 kg) operator.



*9'7" (2,92 m)
with rim dish turned in.

TS820-D Arch Grapple

Standard Equipment

- N.A.F. gear drive dual bogie axles with differential lock, Firestone 28L-26/14 ply tires, and 40,000 lb. (18 144 kg) capacity.
- Superior custom designed gearbox.
- Hydrostatic wheel drive with a Rexroth 125cc 80 gpm (303 litres) pump and Rexroth A6VM160 2-speed auto-shift drive motors with 53,795 lb. (24 401 kg) drawbar pull and 0-9.0 mph (14.48 km/h) travel speed.
- Cummins C8.3-C 260HP (193 kW) Elite engine with 130 Amp alternator.
- Rexroth AA11V095 62 gpm (235 litres) implement pump and 6-section VOAC LS90 main control valve.
- 25 ft². (2,32 m²) capacity arch grapple.
- Excellent component accessibility for easy service and maintenance.
- Strongest, safest cab in the industry with full ROPS/FOPS/OPS certification, excellent visibility, 3 emergency escapes, and rubber isolator mounted for sound suppression. Other features include a Red Dot air conditioner and heater, AM/FM radio with cassette, and full halogen lighting package.
- 109 gal. (412 litres) fuel capacity.

Optional Equipment

- 4 different wheel combinations including a dual wheel configuration.
- Fire Suppression system.
- Cold weather starting aids.
- Heavy-duty frame lock brake caliper.
- Extended machine warranty.

Sold and Serviced By:

Ground Pressures

	Front Axle Empty / Max. Load	Rear Axle Empty / Max. Load	Front Axle w/Tracks Empty / Max. Load	Rear Axle w/Tracks Empty / Max. Load
Firestone 28L-26 (Standard).....	8.19 psi / 8.19 psi	5.82 psi / 11.24 psi	5.68 psi / 5.68 psi	3.94 psi / 7.50 psi
Firestone 28L-26 & 23.1 Dual.....	4.70 psi / 4.70 psi	4.16 psi / 7.16 psi	---	---
Firestone 700/50-26.5.....	12.85 psi / 12.85 psi	11.16 psi / 20.61 psi	6.39 psi / 6.39 psi	5.65 psi / 9.75 psi
Nokian 750/55-26.5.....	9.99 psi / 9.99 psi	8.70 psi / 15.89 psi	6.30 psi / 6.30 psi	4.92 psi / 8.35 psi
Firestone 54 x 37.....	7.75 psi / 7.75 psi	6.78 psi / 12.21 psi	---	---

